

# MSP

## Standard Mine-Duty Precleaner

### Economical and Effective

The MSP Standard-Duty Precleaner is not your average solid-blade belt cleaner that mounts on the head pulley. It is a mine-tough design that combines simple, do-it-yourself installation, quick maintenance and effective cleaning results with an affordable price tag.



**Faceted profile design** results in continuous blade edge "renewal" for improved cleaning efficiency throughout the life of the blade

**Molded in wear line** on all Flexco ConShear™ blades

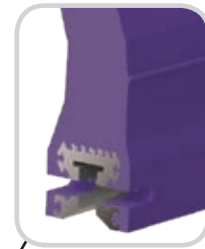

**High strength aluminum extrusion**

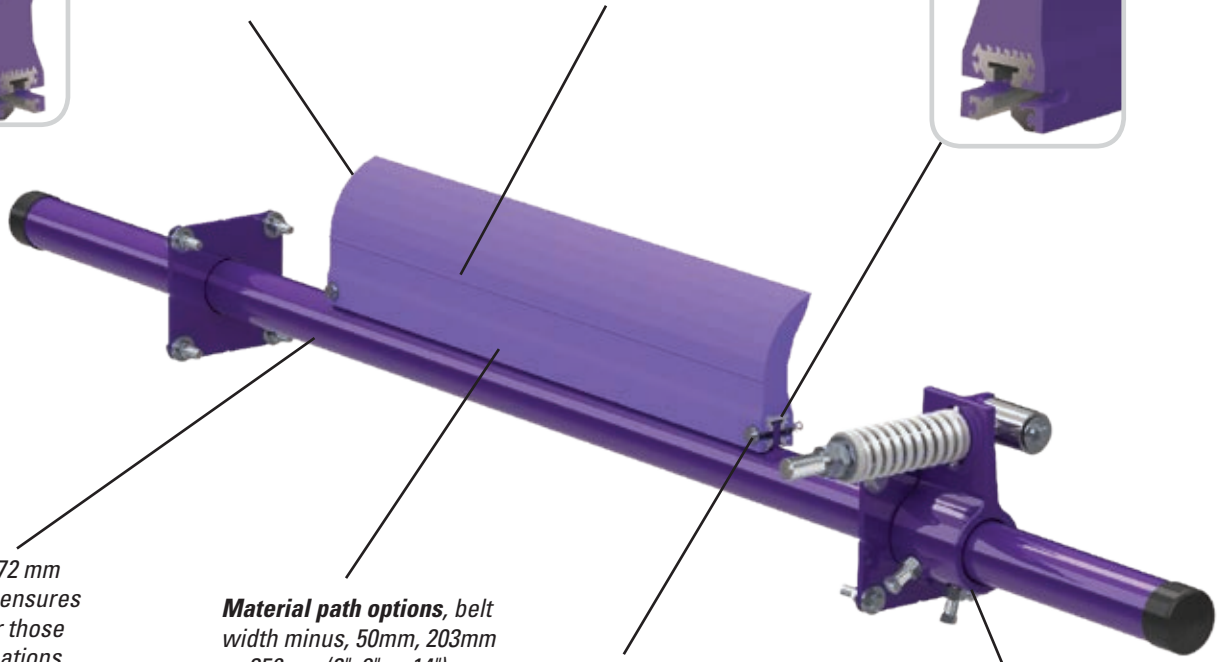

**Heavy-duty 72 mm (2-7/8") pole** ensures durability for those tough applications

**Material path options**, belt width minus, 50mm, 203mm or 356mm (2", 8" or 14"), guarantee proper cleaning and blade life

**Simple blade replacement - no tools needed**

### Features and Benefits

- **Quick-change blade.** No tools are needed. Just pull one pin, remove the old blade, slide in the new one and replace the pin.
- **Works with Flexco and other mechanical splices.** The spring tensioner quickly moves the blade away from the belt when a splice passes. The polyurethane blade easily glides over the splice without damage and with minimal cleaning disruption.
- **Easy to service.** All maintenance work is done from the easy-access side of the beltline. Blade retensioning and change-out are quick and easy.
- **Fits most conveyor structures.** Available for belt widths from 600 to 2100mm (24" to 84"). The MSP poles are extra long (belt width plus 1350mm/54") to accommodate varying structure widths.



**Quick Mount Tensioner (QMT)** allows the blade tension to be visually inspected

# MSP Standard Mine-Duty Precleaner

## Specifications and Guidelines

- **Maximum Belt Speed**  
3.5 m/s (700 FPM)
- **Temperature Rating**  
-35°C to 82°C (-30°F to 180°F)
- **Minimum Pulley Diameter**  
400mm (16")
- **Blade Height**  
185mm (7-1/4")
- **Usable Blade Wear Length**  
100mm (4")
- **Blade Material**  
Polyurethane 83 durometer (proprietary blend for abrasion resistance and long wear)
- **Available for Belt Widths**  
600 to 2100mm (24" to 84")
- **Horizontal Clearance Required**  
100mm (4")
- **Vertical Clearance Required**  
254mm (10")
- **Pole Length**  
Cleaner size + 1350mm (54")
- **Maximum Conveyor Span**  
Cleaner size + 1100mm (44")
- **CEMA Cleaner Rating**  
Class 3

### Pole Location Specs

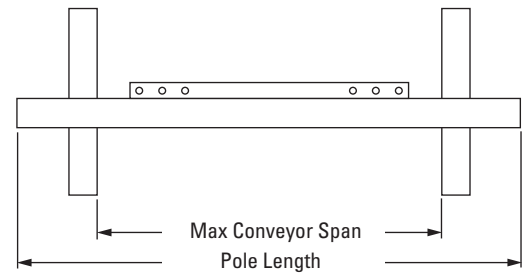
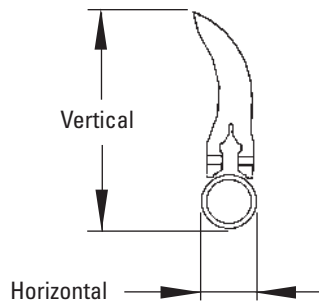
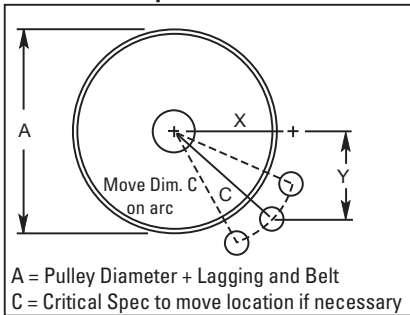

### Pole Location Chart

A	X	Y	C	A	X	Y	C	A	X	Y	C
400	204	305	367	625	314	230	390	850	446	230	501
425	218	305	375	650	330	230	402	875	460	230	514
450	231	305	383	675	346	230	415	900	474	230	526
475	244	305	390	700	360	230	427	925	488	230	539
500	259	305	400	725	374	230	439	950	502	230	552
525	274	305	410	775	389	230	452	975	516	230	565
550	288	305	419	775	403	230	464	1000	529	230	576
575	300	305	428	825	417	230	477	1025	542	230	589
600	315	305	438	825	432	230	489	1050	557	230	602

### Ordering Information

MSP Standard-Duty Precleaner  
Belt Width Minus 50mm (2")

Belt Width	Blade Width	Ordering Number	Item Code
mm	in.		
600	24	MSP-600-50	81000
750	30	MSP-750-50	81001
900	36	MSP-900-50	81002
1050	42	MSP-1050-50	81003
1200	48	MSP-1200-50	81004
1350	54	MSP-1350-50	81005
1500	60	MSP-1500-50	81006
1800	72	MSP-1800-50	81007
2100	84	MSP-2100-50	81008

MSP Standard-Duty Precleaner  
Belt Width Minus 200mm (8")

Belt Width	Blade Width	Ordering Number	Item Code
mm	in.		
600	24	MSP-600-200	81009
750	30	MSP-750-200	81010
900	36	MSP-900-200	81011
1050	42	MSP-1050-200	81012
1200	48	MSP-1200-200	81013
1350	54	MSP-1350-200	81014
1500	60	MSP-1500-200	81015
1800	72	MSP-1800-200	81017
2100	84	MSP-2100-200	81018

### Replacement ConShear™ Blades

Blade Width	Ordering Number	Item Code	
mm	in.		
300	16	CRB-16	75629
350	22	CRB-22	75630
450	28	CRB-28	75631
600	34	CRB-34	75632
750	40	CRB-40	75633
800	46	CRB-46	75634
950	52	CRB-52	75635
1000	58	CRB-58	75636
1150	64	CRB-64	75775
1200	70	CRB-70	75773
1350	76	CRB-76	76940
1400	82	CRB-82	76941

Other blade sizes available upon request.

Authorized Distributor:

2 Woodlands Sector 1 • #01-21 • Woodlands Spectrum I • Singapore 738068  
Tel: +65-6484-1533 • Fax: +65-6484-1531 • E-mail: [asiasales@flexco.com](mailto:asiasales@flexco.com)

Visit [www.flexco.com](http://www.flexco.com) for other Flexco locations and products.

©2018 Flexible Steel Lacing Company. 03/05/18. For reorder: X5056

